

N69200 Series High Performance High Power Programmable DC Electronic Load

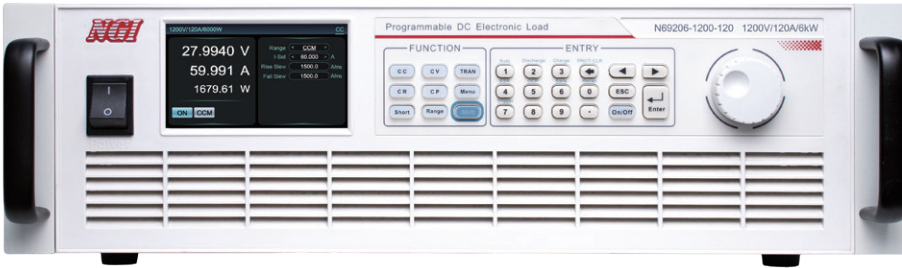

Product Introduction

N69200 series is a high performance high power programmable DC electronic load with high reliability, high precision and multi-function. N69200 series has three voltage specifications: 150V/600V/1200V/1600V/2400V. It can be up to 6kW in standard 3U and 19 inch chassis, supporting parallel control and can realize power expansion through master+master and master+slave. N69200 supports three ranges of voltage, current, power and resistance, and provides high-precision measurement, which makes the test range wider of a single unit. N69200 has adjustable CV loop speed, fast current rise and fall speed, 8 operation modes, supports sequence test, dynamic test, discharge test, charge test, OCP/OPP test, short-circuit simulation, equivalent DC internal resistance (DCIR) test (optional), arbitrary waveform load test, etc. It supports local/remote control, with LAN/RS232/CAN interface, USB HOST interface (waveform import), digital input and output interface, analog input and output interface as standard, and optional GPIB interface as optional. N69200 series adopts standard 3U height 19-inch width chassis, based on modular design concept, doubles the power density, and develops various functions, together with the powerful product performance index, it can effectively solve various needs in testing, and it is a trustworthy product for R&D testing and ATE testing system.

Application Fields

- ▶ New energy fields, such as fuel cell stacks and engines, lithium battery packs, supercapacitors, photovoltaic modules, etc.
- ▶ High-power DC power supply, such as industrial power supply, server power supply, communication power supply, etc.
- ▶ Power electronic products, such as UPS power supply, DC-DC converter, on-board charger, etc.
- ▶ Power supply, such as generator set, energy storage system, DC charging pile, etc.
- ▶ DC high-power devices, such as contactors/relays, automotive high-voltage accessories, etc.
- ▶ Electric vehicles, semiconductors, aerospace, etc.

Main Features

- ▶ Standalone input power: 2~60kW, 3U/6kW high power density
- ▶ Voltage range: 0~150V/0~600V/0~1200V/0~1600V/0~2400V
- ▶ Current range: up to 2500A
- ▶ CV, CC, CP, CR three ranges, wide measurement range
- ▶ Voltage measurement accuracy: 0.015%+0.015% F.S.
- ▶ Current measurement accuracy: 0.04%+0.04% F.S.
- ▶ 1.6 times power loading capacity in a short time (<3s)
- ▶ Adjustable CV loop speed, matching different power supplies
- ▶ Supporting parallel control, and realizing power expansion via master+master, master+slave
- ▶ Operation modes: CC, CV, CP, CR, CV+CC, CR+CC, CV+CR, CP+CC
- ▶ Supporting SEQ test, discharge test, charge test, OCP/OPP test and short-circuit simulation
- ▶ Supporting current monitoring output, external programming input, external trigger input, and 10kHz sine wave programming input
- ▶ 30kHz high-speed dynamic mode, dynamic frequency sweep function
- ▶ Time measurement, rise/fall time measurement accuracy: 10μs
- ▶ Equivalent DC internal resistance (DCIR) test (optional)
- ▶ Arbitrary waveform load test, sine wave up to 20kHz, supporting USB flash drive import
- ▶ Soft on/off function, current oscillation protection function

- ▶ Support optional NP101 series module to achieve 0V with load ^[1]
- ▶ Multiple protection: OCP, OVP, OPP, OTP and reverse connection detection
- ▶ Supporting 100 groups of parameters to be saved when powered off and easy to recall
- ▶ LAN/RS232/CAN as standard interface, GPIB as optional interface
- ▶ Supporting MPPT maximum power point tracking function

Note [1]: Supported by some 150V models only

3U/6kW, ultra-high power density

N69200 is designed with high power density. Power of 19" 3U chassis can be up to 6kW. The volume and weight are half of traditional electronic loads. Compared with traditional electronic loads with the same power, N69200 is smaller in size and lighter in weight.



Parallel connection for power extension

N69200 supports parallel connection. When the load power needs to be increased, models with the same voltage specification can be connected in parallel (master + master, master + slave) to achieve the required current and power. When using N69200, users only needs to set current on the master. The slave current will be distributed automatically, which simplifies the operation steps.

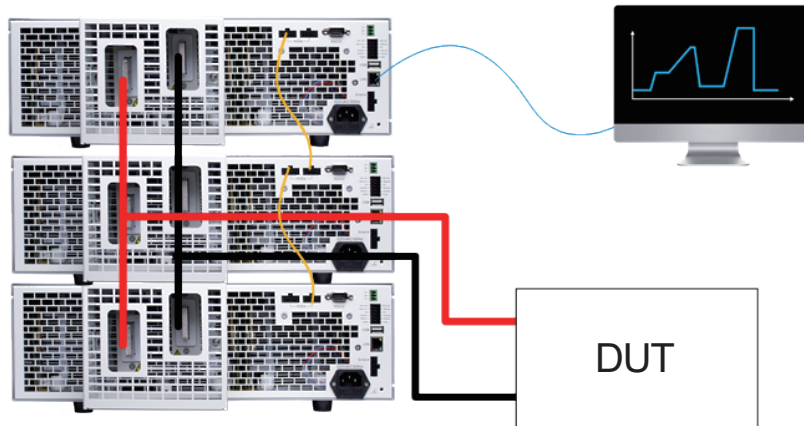

▲ Master+Master Parallel Connection Diagram

Multiple operating modes for multiple test scenarios

N69200 supports four normal working modes: CC, CV, CP, and CR. In order to cope with the change of load characteristics in the actual test process, N69200 has also been developed with CV+CC, CR+CC, CV+CR, CP+CC four combined working modes. For example, CR+CC is suitable for the startup test of power supply to prevent overcurrent protection when the power supply is turned on. CV+CR can replace the setting application of Von point. CV+CC can simulate the working mode transition process of battery charging. Users can choose different working modes for test according to their actual situation.

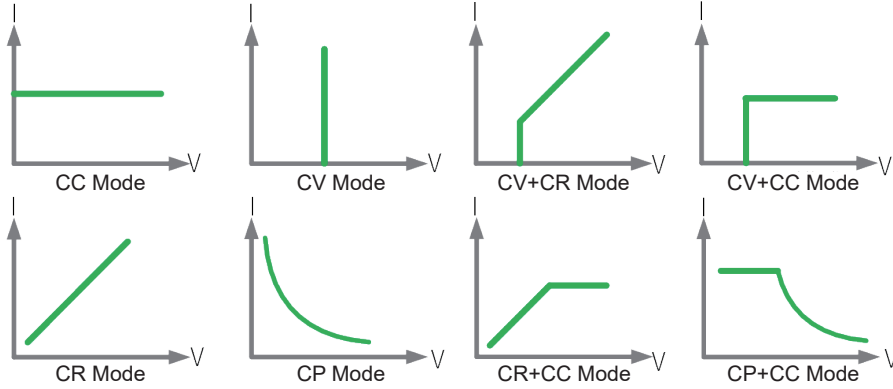

High speed dynamic mode, with dynamic frequency sweep

N69200 has a high-speed dynamic mode. The dynamic characteristics of the DC power supply can be tested by simulating the dynamic load behavior of the power supply through the dynamic mode. N69200 provides dynamic frequency sweep and programmable dynamic mode up to 30kHz, including CCD constant current dynamic, CVD constant voltage dynamic, CRD constant resistance dynamic, and CPD constant power dynamic. Programmable dynamic load mode allows setting of high/low range, rise/fall slew rate, pulse width and operation mode. The voltage and current sampling rate of dynamic frequency sweep mode is 500kHz. It supports linearly changing the frequency of the load current. Frequency is up to 30kHz. This mode can measure the peak voltage V_{pk+} , valley voltage V_{pk-} and occurrence frequency points of the DUT during the dynamic frequency load change process.

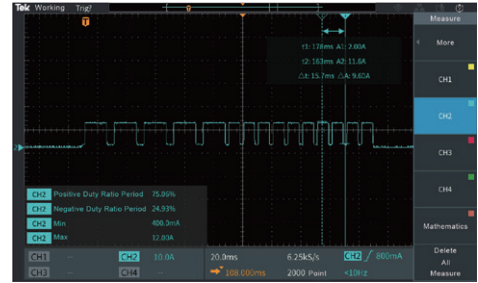

▲ Sweep Mode

Charge/discharge test, built-in battery test mode

Users can set different conditions on the front panel to meet their test demands. For example, when battery voltage is lower than initial voltage, N69200 internal counter will start counting. The counter will stop working until the battery voltage drops to cut-off voltage.

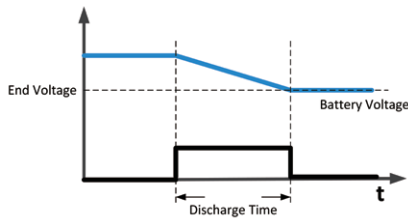

▲ Discharge Test Graph

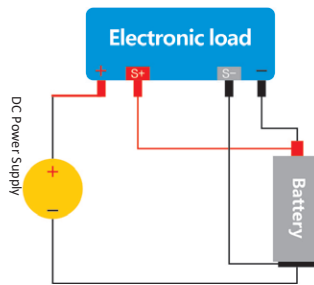

▲ Charge Wiring

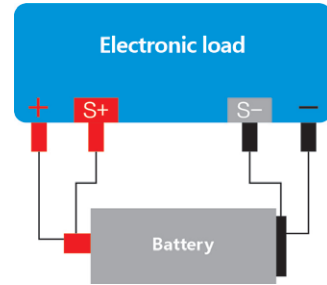

▲ Discharge Wiring

OCP (over current protection) test

During OCP test, N69200 will load under CC mode and check whether the DUT voltage is lower than cut-off voltage. If lower, N69200 will record the present loading current as the test result and shut the input to stop the test. If the DUT voltage is higher than cut-off voltage, N69200 will increase the loading current until the DUT voltage is lower than cut-off voltage or it reaches the Max. loading current.

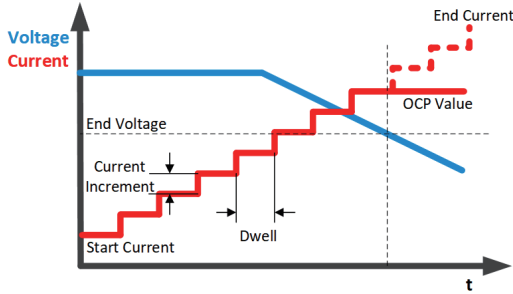

▲ OCP Test Diagram



▲ OCP Test Interface

Equivalent Series Resistance (ESR) test (Optional)

ESR is a principal parameter of battery or supercapacitor. N69200 series offers professional ESR measurement function, which can support multiple measurement standards, and possess the advantages of accurate results and stable repeated results.

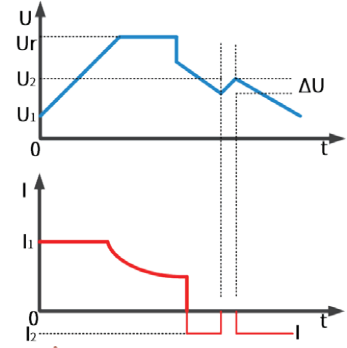

▲ ESR Test schematic diagram

DC Electronic Load

Quick Selection

150V Model	Specification	Size	600V Model	Specification	Size
N69202-150-200	2kW/150V/200A	3U	N69202-600-140	2kW/600V/140A	3U
N69204-150-400	4kW/150V/400A	3U	N69204-600-280	4kW/600V/280A	3U
N69206-150-600	6kW/150V/600A	3U	N69206-600-420	6kW/600V/420A	3U
N69212-150-1200	12kW/150V/1200A	6U	N69212-600-840	12kW/600V/840A	6U
N69218-150-1800	18kW/150V/1800A	9U	N69218-600-1260	18kW/600V/1260A	9U
N69224-150-2400	24kW/150V/2400A	12U	N69224-600-1680	24kW/600V/1680A	12U
N69230-150-2500	30kW/150V/2500A	22U	N69230-600-2100	30kW/600V/2100A	22U
N69236-150-2500	36kW/150V/2500A	22U	N69236-600-2500	36kW/600V/2500A	22U
N69242-150-2500	42kW/150V/2500A	22U	N69242-600-2500	42kW/600V/2500A	22U
N69248-150-2500	48kW/150V/2500A	32U	N69248-600-2500	48kW/600V/2500A	32U
N69254-150-2500	54kW/150V/2500A	32U	N69254-600-2500	54kW/600V/2500A	32U
N69260-150-2500	60kW/150V/2500A	32U	N69260-600-2500	60kW/600V/2500A	32U

1200V Model	Specification	Size		Specification	Size
N69202-1200-40	2kW/1200V/40A	3U	N69230-1200-600	30kW/1200V/600A	22U
N69202-1200-80	2kW/1200V/80A	3U	N69230-1200-1200	30kW/1200V/1200A	22U
N69204-1200-80	4kW/1200V/80A	3U	N69236-1200-720	36kW/1200V/720A	22U
N69204-1200-160	4kW/1200V/160A	3U	N69236-1200-1440	36kW/1200V/1440A	22U
N69206-1200-120	6kW/1200V/120A	3U	N69242-1200-840	42kW/1200V/840A	22U
N69206-1200-240	6kW/1200V/240A	3U	N69242-1200-1680	42kW/1200V/1680A	22U
N69212-1200-240	12kW/1200V/240A	6U	N69248-1200-960	48kW/1200V/960A	32U
N69212-1200-480	12kW/1200V/480A	6U	N69248-1200-1920	48kW/1200V/1920A	32U
N69218-1200-360	18kW/1200V/360A	9U	N69254-1200-1080	54kW/1200V/1080A	32U
N69218-1200-720	18kW/1200V/720A	9U	N69254-1200-2160	54kW/1200V/2160A	32U
N69224-1200-480	24kW/1200V/480A	12U	N69260-1200-1200	60kW/1200V/1200A	32U
N69224-1200-960	24kW/1200V/960A	12U	N69260-1200-2400	60kW/1200V/2400A	32U

1600V Model	Specification	Size	2400V Model	Specification	Size
N69203-1600-40	3kW/1600V/40A	3U	N69203-2400-40	3kW/2400V/40A	3U
N69205-1600-60	5kW/1600V/60A	3U	N69205-2400-60	5kW/2400V/60A	3U
N69210-1600-120	10kW/1600V/120A	6U	N69210-2400-120	10kW/2400V/120A	6U
N69215-1600-180	15kW/1600V/180A	9U	N69215-2400-180	15kW/2400V/180A	9U
N69220-1600-240	20kW/1600V/240A	12U	N69220-2400-240	20kW/2400V/240A	12U
N69225-1600-300	25kW/1600V/300A	22U	N69225-2400-300	25kW/2400V/300A	22U
N69230-1600-360	30kW/1600V/360A	22U	N69230-2400-360	30kW/2400V/360A	22U
N69235-1600-420	35kW/1600V/420A	22U	N69235-2400-420	35kW/2400V/420A	22U
N69240-1600-480	40kW/1600V/480A	32U	N69240-2400-480	40kW/2400V/480A	32U
N69245-1600-540	45kW/1600V/540A	32U	N69245-2400-540	45kW/2400V/540A	32U
N69250-1600-600	50kW/1600V/600A	32U	N69250-2400-600	50kW/2400V/600A	32U

0V with Load Selection

Model	Module	Size	Model	Module	Size
N69206-150-600	NP101-600	6U	N69210-150-1000	NP101-1000	9U
N69208-150-800	NP101-800	9U	N69212-150-1200	NP101-1200	9U

*N69200 series supports parallel power expansion, for more power product selection, please contact us

Product Dimension

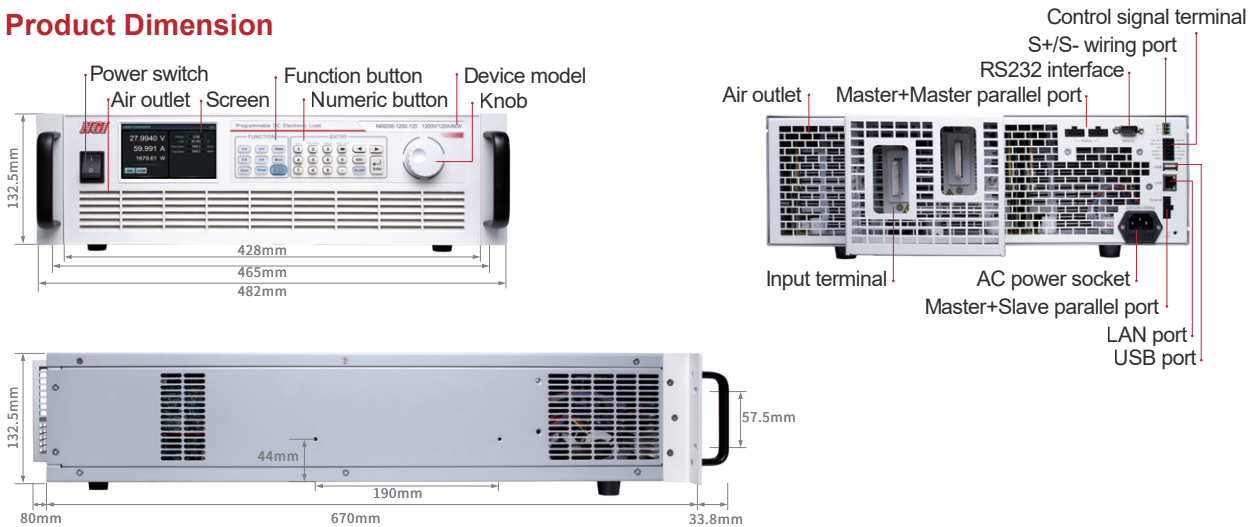

Technical Data Sheet(1)

Model	N69202-150-200			N69202-600-140			N69202-1200-40		
Voltage	150V			600V			1200V		
Current	200A			140A			40A		
Power	2000W								
Min. Operating Voltage	2V@200A			14V@140A			30V@40A		
CV Mode									
Range	0~15V	0~75V	0~150V	0~60V	0~300V	0~600V	0~120V	0~600V	0~1200V
Setting Resolution	1mV	1mV	10mV	1mV	10mV	10mV	10mV	10mV	100mV
Setting Accuracy (23±5°C)	0.025%+0.025%F.S.								
Readback Resolution	0.1mV	0.1mV	1mV	0.1mV	1mV	1mV	1mV	1mV	10mV
Readback Accuracy(23±5°C)	0.015%+0.015%F.S.								
CC Mode									
Range	0~20A	0~100A	0~200A	0~14A	0~70A	0~140A	0~4A	0~20A	0~40A
Setting Resolution	1mA	10mA	10mA	1mA	1mA	10mA	0.1mA	1mA	1mA
Setting Accuracy (23±5°C)	0.05%+0.05%F.S.								
Readback Resolution	0.1mA	1mA	1mA	0.1mA	0.1mA	1mA	0.01mA	0.1mA	0.1mA
Readback Accuracy(23±5°C)	0.04%+0.04%F.S.								
CP Mode									
Range	200W	1000W	2000W	200W	1000W	2000W	200W	1000W	2000W
Setting Resolution	0.01W	0.1W	0.1W	0.01W	0.1W	0.1W	0.01W	0.1W	0.1W
Setting Accuracy (23±5°C)	0.2%+0.2%F.S.								
Readback Resolution	0.001W	0.01W	0.01W	0.001W	0.01W	0.01W	0.001W	0.01W	0.01W
Readback Accuracy(23±5°C)	0.1%+0.1%F.S.								
CR Mode									
Range	0.1Ω~3750Ω	0.02Ω~750Ω	0.01Ω~375Ω	1Ω~21429Ω	0.2Ω~4286Ω	0.1Ω~2143Ω	8Ω~150000Ω	2Ω~30000Ω	1Ω~15000Ω
Setting Resolution	0.1Ω	0.01Ω	0.01Ω	1Ω	0.1Ω	0.1Ω	10Ω	1Ω	0.1Ω
Setting Accuracy (23±5°C)	(Vin/Rset)*0.05%+0.05%IF.S.								
Slew Rate									
Current	0.001~1000A/ms	0.001~5000A/ms	0.001~10000A/ms	0.001~700A/ms	0.001~3500A/ms	0.001~7000A/ms	0.001~300A/ms	0.001~1500A/ms	0.001~3000A/ms
Power	0.001~1000A/ms	0.001~5000A/ms	0.001~10000A/ms	0.001~700A/ms	0.001~3500A/ms	0.001~7000A/ms	0.001~300A/ms	0.001~1500A/ms	0.001~3000A/ms
Resistance	0.001~1000A/ms	0.001~5000A/ms	0.001~10000A/ms	0.001~700A/ms	0.001~3500A/ms	0.001~7000A/ms	0.001~300A/ms	0.001~1500A/ms	0.001~3000A/ms
CCD Mode									
T1&T2	0.025ms~60000s								
Resolution	1μs								
Accuracy (23±5°C)	10μs+100ppm								
Rise/Fall Slew Rate	0.001~1000A/ms	0.001~5000A/ms	0.001~10000A/ms	0.001~700A/ms	0.001~3500A/ms	0.001~7000A/ms	0.001~300A/ms	0.001~1500A/ms	0.001~3000A/ms
Min. Rise Time	30μs								
Others									
Input Impedance	0.3MΩ(Typical)			1MΩ(Typical)			1.6MΩ(Typical)		
Protection Function	OVP/OCP/OPP/OTP/RV								
Interface	USB(Waveform import)/LAN/RS232/CAN								
Communication Protocol	Modbus-RTU standard protocol, CANOPEN standard protocol, SCPI standard protocol								
Communication Response Time	≤5ms								
AC Input	Voltage 220V AC ± 10%, current < 2A, frequency 47Hz~63Hz								
Temperature	Operating temperature: 0°C~40°C, storage temperature: -20°C~60°C								
Operating Environment	Altitude <2000m, relative humidity: 5%~90%RH(non-condensing), atmospheric pressure: 80~110kPa								
Net Weight	Approx. 22kg								
Dimension	3U, 132.5(H)*482.0(W)with handle*783.8(D)mm								

Note 1: For other specifications, please contact NGI.

Note 2: All specifications are subject to change without notice.

Technical Data Sheet(2)

Model	N69204-150-400			N69204-600-280			N69204-1200-80		
Voltage	150V			600V			1200V		
Current	400A			280A			80A		
Power	4000W								
Min. Operating Voltage	2V@400A			14V@280A			30V@80A		
CV Mode									
Range	0~15V	0~75V	0~150V	0~60V	0~300V	0~600V	0~120V	0~600V	0~1200V
Setting Resolution	1mV	1mV	10mV	1mV	10mV	10mV	10mV	10mV	100mV
Setting Accuracy (23±5°C)	0.025%+0.025%F.S.								
Readback Resolution	0.1mV	0.1mV	1mV	0.1mV	1mV	1mV	1mV	1mV	10mV
Readback Accuracy(23±5°C)	0.015%+0.015%F.S.								
CC Mode									
Range	0~40A	0~200A	0~400A	0~28A	0~140A	0~280A	0~8A	0~40A	0~80A
Setting Resolution	1mA	10mA	10mA	1mA	10mA	10mA	0.1mA	1mA	1mA
Setting Accuracy (23±5°C)	0.05%+0.05%F.S.								
Readback Resolution	0.1mA	1mA	1mA	0.1mA	1mA	1mA	0.01mA	0.1mA	0.1mA
Readback Accuracy(23±5°C)	0.04%+0.04%F.S.								
CP Mode									
Range	400W	2000W	4000W	400W	2000W	4000W	400W	2000W	4000W
Setting Resolution	0.01W	0.1W	0.1W	0.01W	0.1W	0.1W	0.01W	0.1W	0.1W
Setting Accuracy (23±5°C)	0.2%+0.2%F.S.								
Readback Resolution	0.001W	0.01W	0.01W	0.001W	0.01W	0.01W	0.001W	0.01W	0.01W
Readback Accuracy(23±5°C)	0.1%+0.1%F.S.								
CR Mode									
Range	0.1Ω~1875Ω	0.01Ω~375Ω	0.01Ω~188Ω	1Ω~10715Ω	0.1Ω~2143Ω	0.1Ω~1072Ω	4Ω~75000Ω	1Ω~15000Ω	0.4Ω~7500Ω
Setting Resolution	0.1Ω	0.01Ω	0.01Ω	1Ω	0.1Ω	0.1Ω	1Ω	1Ω	0.1Ω
Setting Accuracy (23±5°C)	(Vin/Rset)*0.05%+0.05%IF.S.								
Slew Rate									
Current	0.001~2000A/ms	0.001~10000A/ms	0.001~20000A/ms	0.001~1400A/ms	0.001~7000A/ms	0.001~14000A/ms	0.001~600A/ms	0.001~3000A/ms	0.001~6000A/ms
Power	0.001~2000A/ms	0.001~10000A/ms	0.001~20000A/ms	0.001~1400A/ms	0.001~7000A/ms	0.001~14000A/ms	0.001~600A/ms	0.001~3000A/ms	0.001~6000A/ms
Resistance	0.001~2000A/ms	0.001~10000A/ms	0.001~20000A/ms	0.001~1400A/ms	0.001~7000A/ms	0.001~14000A/ms	0.001~600A/ms	0.001~3000A/ms	0.001~6000A/ms
CCD Mode									
T1&T2	0.025ms~60000s								
Resolution	1μs								
Accuracy (23±5°C)	10μs+100ppm								
Rise/Fall Slew Rate	0.001~2000A/ms	0.001~10000A/ms	0.001~20000A/ms	0.001~1400A/ms	0.001~7000A/ms	0.001~14000A/ms	0.001~600A/ms	0.001~3000A/ms	0.001~6000A/ms
Min. Rise Time	30μs								
Others									
Input Impedance	0.3MΩ(Typical)			1MΩ(Typical)			1.6MΩ(Typical)		
Protection Function	OVP/OCP/OPP/OTP/RV								
Interface	USB(Waveform import)/LAN/RS232/CAN								
Communication Protocol	Modbus-RTU standard protocol, CANOPEN standard protocol, SCPI standard protocol								
Communication Response Time	≤5ms								
AC Input	Voltage 220V AC ± 10%, current < 2A, frequency 47Hz~63Hz								
Temperature	Operating temperature: 0°C~40°C, storage temperature: -20°C~60°C								
Operating Environment	Altitude <2000m, relative humidity: 5%~90%RH(non-condensing), atmospheric pressure: 80~110kPa								
Net Weight	Approx. 28kg								
Dimension	3U, 132.5(H)*482.0(W)with handle*783.8(D)mm(with output shield)								

Note 1: For other specifications, please contact NGI.

Note 2: All specifications are subject to change without notice.

Technical Data Sheet(3)

Model	N69206-150-600			N69206-600-420			N69206-1200-120		
Voltage	150V			600V			1200V		
Current	600A			420A			120A		
Power	6000W								
Min. Operating Voltage	2V@600A			14V@420A			30V@120A		
CV Mode									
Range	0~15V	0~75V	0~150V	0~60V	0~300V	0~600V	0~120V	0~600V	0~1200V
Setting Resolution	1mV	1mV	10mV	1mV	10mV	10mV	10mV	10mV	100mV
Setting Accuracy(23±5℃)	0.025%+0.025%F.S.								
Readback Resolution	0.1mV	0.1mV	1mV	0.1mV	1mV	1mV	1mV	1mV	10mV
Readback Accuracy(23±5℃)	0.015%+0.015%F.S.								
CC Mode									
Range	0~60A	0~300A	0~600A	0~42A	0~210A	0~420A	0~12A	0~60A	0~120A
Setting Resolution	1mA	10mA	10mA	1mA	10mA	10mA	1mA	1mA	10mA
Setting Accuracy(23±5℃)	0.05%+0.05%F.S.								
Readback Resolution	0.1mA	1mA	1mA	0.1mA	1mA	1mA	0.1mA	0.1mA	1mA
Readback Accuracy(23±5℃)	0.04%+0.04%F.S.								
CP Mode									
Range	600W	3000W	6000W	600W	3000W	6000W	600W	3000W	6000W
Setting Resolution	0.01W	0.1W	0.1W	0.01W	0.1W	0.1W	0.01W	0.1W	0.1W
Setting Accuracy(23±5℃)	0.2%+0.2%F.S.								
Readback Resolution	0.001W	0.01W	0.01W	0.001W	0.01W	0.01W	0.001W	0.01W	0.01W
Readback Accuracy(23±5℃)	0.1%+0.1%F.S.								
CR Mode									
Range	0.1Ω~1250Ω	0.01Ω~250Ω	0.01Ω~125Ω	0.4Ω~7143Ω	0.1Ω~1429Ω	0.04Ω~715Ω	3Ω~50000Ω	1Ω~10000Ω	0.3Ω~5000Ω
Setting Resolution	0.1Ω	0.01Ω	0.01Ω	0.1Ω	0.1Ω	0.01Ω	1Ω	1Ω	0.1Ω
Setting Accuracy(23±5℃)	(Vin/Rset)*0.05%+0.05%IF.S.								
Slew Rate									
Current	0.001~3000A/ms	0.001~15000A/ms	0.001~30000A/ms	0.001~2100A/ms	0.001~10500A/ms	0.001~21000A/ms	0.001~900A/ms	0.001~4500A/ms	0.001~9000A/ms
Power	0.001~3000A/ms	0.001~15000A/ms	0.001~30000A/ms	0.001~2100A/ms	0.001~10500A/ms	0.001~21000A/ms	0.001~900A/ms	0.001~4500A/ms	0.001~9000A/ms
Resistance	0.001~3000A/ms	0.001~15000A/ms	0.001~30000A/ms	0.001~2100A/ms	0.001~10500A/ms	0.001~21000A/ms	0.001~900A/ms	0.001~4500A/ms	0.001~9000A/ms
CCD Mode									
T1&T2	0.025ms~60000s								
Resolution	1μs								
Accuracy(23±5℃)	10μs+100ppm								
Rise/Fall Slew Rate	0.001~3000A/ms	0.001~15000A/ms	0.001~30000A/ms	0.001~2100A/ms	0.001~10500A/ms	0.001~21000A/ms	0.001~900A/ms	0.001~4500A/ms	0.001~9000A/ms
Min. Rise Time	30μs								
Others									
Input Impedance	0.3MΩ(Typical)			1MΩ(Typical)			1.6MΩ(Typical)		
Protection Function	OVP/OCP/OPP/OTP/RV								
Interface	USB(Waveform import)/LAN/RS232/CAN								
Communication Protocol	Modbus-RTU standard protocol, CANOPEN standard protocol, SCPI standard protocol								
Communication Response Time	≤5ms								
AC Input	Voltage 220V AC ± 10%, current < 2A, frequency 47Hz~63Hz								
Temperature	Operating temperature: 0℃~40℃, storage temperature: -20℃~60℃								
Operating Environment	Altitude <2000m, relative humidity: 5%~90%RH(non-condensing), atmospheric pressure: 80~110kPa								
Net Weight	Approx. 34kg								
Dimension	3U, 132.5(H)*482.0(W)with handle*783.8(D)mm(with output shield)								

Note 1: For other specifications, please contact NGI.

Note 2: All specifications are subject to change without notice.

Technical Data Sheet(4)

Model	N69202-1200-80			N69204-1200-160			N69206-1200-240		
Voltage	1200V								
Current	80A			160A			240A		
Power	2000W			4000W			6000W		
Min. Operating Voltage	25V@80A			25V@160A			25V@240A		
CV Mode									
Range	0~120V	0~600V	0~1200V	0~120V	0~600V	0~1200V	0~120V	0~600V	0~1200V
Setting Resolution	10mV	10mV	100mV	10mV	10mV	100mV	10mV	10mV	100mV
Setting Accuracy(23±5℃)	0.025%+0.025%F.S.								
Readback Resolution	1mV	1mV	10mV	1mV	1mV	10mV	1mV	1mV	10mV
Readback Accuracy(23±5℃)	0.015%+0.015%F.S.								
CC Mode									
Range	0~8A	0~40A	0~80A	0~16A	0~80A	0~160A	0~24A	0~120A	0~240A
Setting Resolution	0.1mA	1mA	1mA	1mA	1mA	10mA	1mA	10mA	10mA
Setting Accuracy(23±5℃)	0.05%+0.05%F.S.								
Readback Resolution	0.01mA	0.1mA	0.1mA	0.1mA	0.1mA	1mA	0.1mA	1mA	1mA
Readback Accuracy(23±5℃)	0.04%+0.04%F.S.								
CP Mode									
Range	200W	1000W	2000W	400W	2000W	4000W	600W	3000W	6000W
Setting Resolution	0.01W	0.1W	0.1W	0.01W	0.1W	0.1W	0.01W	0.1W	0.1W
Setting Accuracy(23±5℃)	0.2%+0.2%F.S.								
Readback Resolution	0.001W	0.01W	0.01W	0.001W	0.01W	0.01W	0.001W	0.01W	0.01W
Readback Accuracy(23±5℃)	0.1%+0.1%F.S.								
CR Mode									
Range	4Ω~7500Ω	0.7Ω~15000Ω	0.4Ω~7500Ω	2Ω~37500Ω	0.4Ω~7500Ω	0.2Ω~3750Ω	2Ω~25000Ω	0.3Ω~5000Ω	0.2Ω~2500Ω
Setting Resolution	1Ω	1Ω	0.1Ω	1Ω	0.1Ω	0.1Ω	1Ω	0.1Ω	0.1Ω
Setting Accuracy(23±5℃)	(Vin/Rset)*0.05%+0.05%IF.S.								
Slew Rate									
Current	0.001~266.4A/ms	0.001~1332A/ms	0.001~2664A/ms	0.001~532.8A/ms	0.001~2664A/ms	0.001~5328A/ms	0.001~799.2A/ms	0.001~3996A/ms	0.001~7992A/ms
Power	0.001~266.4A/ms	0.001~1332A/ms	0.001~2664A/ms	0.001~532.8A/ms	0.001~2664A/ms	0.001~5328A/ms	0.001~799.2A/ms	0.001~3996A/ms	0.001~7992A/ms
Resistance	0.001~266.4A/ms	0.001~1332A/ms	0.001~2664A/ms	0.001~532.8A/ms	0.001~2664A/ms	0.001~5328A/ms	0.001~799.2A/ms	0.001~3996A/ms	0.001~7992A/ms
CCD Mode									
T1&T2	0.025ms~60000s								
Resolution	1μs								
Accuracy(23±5℃)	10μs+100ppm								
Rise/Fall Slew Rate	0.001~266.4A/ms	0.001~1332A/ms	0.001~2664A/ms	0.001~532.8A/ms	0.001~2664A/ms	0.001~5328A/ms	0.001~799.2A/ms	0.001~3996A/ms	0.001~7992A/ms
Min. Rise Time	30μs								
Others									
Input Impedance	1.6MΩ(Typical)								
Protection Function	OVP/OCP/OPP/OTP/RV								
Interface	USB(Waveform import)/LAN/RS232/CAN								
Communication Protocol	Modbus-RTU standard protocol, CANOPEN standard protocol, SCPI standard protocol								
Communication Response Time	≤5ms								
AC Input	Voltage 220V AC ± 10%, current < 2A, frequency 47Hz~63Hz								
Temperature	Operating temperature: 0℃~40℃, storage temperature: -20℃~60℃								
Operating Environment	Altitude <2000m, relative humidity: 5%~90%RH(non-condensing), atmospheric pressure: 80~110kPa								
Net Weight	Approx. 22kg			Approx. 28kg			Approx. 34kg		
Dimension	3U, 132.5(H)*482.0(W)with handle*783.8(D)mm(with output shield)								

Note 1: For other specifications, please contact NGI.

Note 2: All specifications are subject to change without notice.

Technical Data Sheet(5)

Model	N69203-1600-40			N69203-2400-40		
Voltage	1600V			2400V		
Current	40A					
Power	3000W					
Min. Operating Voltage	40V@40A					
CV Mode						
Range	0~160V	0~800V	0~1600V	0~240V	0~1200V	0~2400V
Setting Resolution	10mV	10mV	100mV	10mV	100mV	100mV
Setting Accuracy(23±5℃)	0.025%+0.025%F.S.					
Readback Resolution	1mV	1mV	10mV	1mV	10mV	100mV
Readback Accuracy(23±5℃)	0.015%+0.015%F.S.					
CC Mode						
Range	0~4A	0~20A	0~40A	0~4A	0~20A	0~40A
Setting Resolution	0.1mA	1mA	1mA	0.1mA	1mA	1mA
Setting Accuracy(23±5℃)	0.05%+0.05%F.S.					
Readback Resolution	0.01mA	0.1mA	0.1mA	0.01mA	0.1mA	0.1mA
Readback Accuracy(23±5℃)	0.04%+0.04%F.S.					
CP Mode						
Range	300W	1500W	3000W	300W	1500W	3000W
Setting Resolution	0.01W	0.1W	0.1W	0.01W	0.1W	0.1W
Setting Accuracy(23±5℃)	0.2%+0.2%F.S.					
Readback Resolution	0.001W	0.01W	0.01W	0.001W	0.01W	0.01W
Readback Accuracy(23±5℃)	0.1%+0.1%F.S.					
CR Mode						
Range	10Ω~99.9kΩ	2Ω~40kΩ	1Ω~20kΩ	10Ω~99.9kΩ	2Ω~60kΩ	1Ω~30kΩ
Setting Resolution	1Ω					
Setting Accuracy(23±5℃)	(Vin/Rset)*0.05%+0.05%IF.S.					
Slew Rate						
Current	0.001~130A/ms	0.001~650A/ms	0.001~1300A/ms	0.001~130A/ms	0.001~650A/ms	0.001~1300A/ms
Power	0.001~130A/ms	0.001~650A/ms	0.001~1300A/ms	0.001~130A/ms	0.001~650A/ms	0.001~1300A/ms
Resistance	0.001~130A/ms	0.001~650A/ms	0.001~1300A/ms	0.001~130A/ms	0.001~650A/ms	0.001~1300A/ms
CCD Mode						
T1&T2	0.025ms~60000s					
Resolution	1μs					
Accuracy(23±5℃)	10μs+100ppm					
Rise/Fall Slew Rate	0.001~130A/ms	0.001~650A/ms	0.001~1300A/ms	0.001~130A/ms	0.001~650A/ms	0.001~1300A/ms
Min. Rise Time	30μs					
Others						
Input Impedance	1MΩ(Typical)					
Protection Function	OVP/OCP/OPP/OTP/RV					
Interface	USB(Waveform import)/LAN/RS232/CAN					
Communication Protocol	Modbus-RTU standard protocol, CANOPEN standard protocol, SCPI standard protocol					
Communication Response Time	≤5ms					
AC Input	Voltage 220V AC ± 10%, current < 2A, frequency 47Hz~63Hz					
Temperature	Operating temperature: 0℃~40℃, storage temperature: -20℃~60℃					
Operating Environment	Altitude <2000m, relative humidity: 5%~90%RH(non-condensing), atmospheric pressure: 80~110kPa					
Net Weight	Approx. 22kg					
Dimension	3U, 132.5(H)*482.0(W)with handle*783.8(D)mm(with output shield)					

Note 1: For other specifications, please contact NGI.

Note 2: All specifications are subject to change without notice.

Technical Data Sheet(6)

Model	N69205-1600-60			N69205-2400-60		
Voltage	1600V			2400V		
Current	60A					
Power	5000W					
Min. Operating Voltage	40V@60A					
CV Mode						
Range	0~160V	0~800V	0~1600V	0~240V	0~1200V	0~2400V
Setting Resolution	10mV	10mV	100mV	10mV	100mV	100mV
Setting Accuracy(23±5℃)	0.025%+0.025%F.S.					
Readback Resolution	1mV	1mV	10mV	1mV	10mV	100mV
Readback Accuracy(23±5℃)	0.015%+0.015%F.S.					
CC Mode						
Range	0~6A	0~30A	0~60A	0~6A	0~30A	0~60A
Setting Resolution	0.1mA	1mA	1mA	0.1mA	1mA	1mA
Setting Accuracy(23±5℃)	0.05%+0.05%F.S.					
Readback Resolution	0.01mA	0.1mA	0.1mA	0.01mA	0.1mA	0.1mA
Readback Accuracy(23±5℃)	0.04%+0.04%F.S.					
CP Mode						
Range	500W	2500W	5000W	500W	2500W	5000W
Setting Resolution	0.01W	0.1W	0.1W	0.01W	0.1W	0.1W
Setting Accuracy(23±5℃)	0.2%+0.2%F.S.					
Readback Resolution	0.001W	0.01W	0.01W	0.001W	0.01W	0.01W
Readback Accuracy(23±5℃)	0.1%+0.1%F.S.					
CR Mode						
Range	7Ω~99.9kΩ	1Ω~20kΩ	0.7Ω~9.999kΩ	7Ω~99.9kΩ	1Ω~20kΩ	0.7Ω~9.999kΩ
Setting Resolution	1Ω	1Ω	0.1Ω	1Ω	1Ω	0.1Ω
Setting Accuracy(23±5℃)	(Vin/Rset)*0.05%+0.05%IF.S.					
Slew Rate						
Current	0.001~200A/ms	0.001~800A/ms	0.001~1800A/ms	0.001~200A/ms	0.001~800A/ms	0.001~1800A/ms
Power	0.001~200A/ms	0.001~800A/ms	0.001~1800A/ms	0.001~200A/ms	0.001~800A/ms	0.001~1800A/ms
Resistance	0.001~200A/ms	0.001~800A/ms	0.001~1800A/ms	0.001~200A/ms	0.001~800A/ms	0.001~1800A/ms
CCD Mode						
T1&T2	0.025ms~60000s					
Resolution	1μs					
Accuracy(23±5℃)	10μs+100ppm					
Rise/Fall Slew Rate	0.001~200A/ms	0.001~800A/ms	0.001~1800A/ms	0.001~200A/ms	0.001~800A/ms	0.001~1800A/ms
Min. Rise Time	30μs					
Others						
Input Impedance	650kΩ(Typical)					
Protection Function	OVP/OCP/OPP/OTP/RV					
Interface	USB(Waveform import)/LAN/RS232/CAN					
Communication Protocol	Modbus-RTU standard protocol, CANOPEN standard protocol, SCPI standard protocol					
Communication Response Time	≤5ms					
AC Input	Voltage 220V AC ± 10%, current < 2A, frequency 47Hz~63Hz					
Temperature	Operating temperature: 0℃~40℃, storage temperature: -20℃~60℃					
Operating Environment	Altitude <2000m, relative humidity: 5%~90%RH(non-condensing), atmospheric pressure: 80~110kPa					
Net Weight	Approx. 34kg					
Dimension	3U, 132.5(H)*482.0(W)with handle*783.8(D)mm(with output shield)					

Note 1: For other specifications, please contact NGI.

Note 2: All specifications are subject to change without notice.